

## Tentamen i TSEI07/TEN1, Digitala Filter

- Time: 2013-05-29, 8-12
- Place: U10, U11
- Teacher: Håkan Johansson, 0703432897
- Aid: Pocket calculator  
Tables and formulas for analog and digital filters  
Söderkvist: Formler & Tabeller  
Ingelstam, Rönngren, Sjöberg: Tefyma  
Ekbohm: Tabeller & Formler NT  
Nordling: Physics Handbook for Science and Engineering  
Strid: Formler & Lexikon  
Mathematical tables
- Number of problems: 7
- Instructions: Maximum 70 points, 30 points required to pass the exam.  
**Note** that a motivation/solution is required to get the maximum number of points for a problem!
- Note** that 10 points obtained at the **seminars** means that the first problem does not have to be solved. In case of 5 points, problems 1(a) and 1(b) do not have to be solved.
- Results: Available by 2013-06-12

- 1
- Indicate in the z-plane typical zero locations for the following digital filters: 5th-order lowpass Cauer filter, 10th-order bandpass Butterworth filter, 7th-order highpass Chebyshev-II filter, 8th-order bandstop Chebyshev-I filter. (2.5 p)
  - An FIR filter is given as:  $H(z) = a_0z^{-3} + a_1z^{-7} + a_0z^{-11}$ . Does the filter have a linear phase response? Can it be used as a highpass filter? Motivate your answers. (2.5 p)
  - State the typical features, advantages, and disadvantages of FIR filters and IIR filters and their realizations. (5 p)
- 2) A digital filter is used to filter an analog signal after sampling it with the sampling frequency  $f_{\text{sample}} = 1/T = 11.2$  kHz. The specification of the filter is:  $f_c = 1$  kHz,  $f_s = 4$  kHz,  $A_{\text{max}} = 0.5$  dB,  $A_{\text{min}} = 70$  dB. Synthesize a digital Chebyshev-I filter that meets the specification. Determine the poles and zeros, and indicate their locations in the z-plane. Use the bilinear transformation  $s = \frac{2z-1}{Tz+1}$ . The filter order should not be higher than necessary. (10 p)
- 3) A filter structure is given according to Fig. 1.
- Draw the signal-flow graph in precedence form. (6 p)
  - Compute the minimal sample period  $T_{\text{min}}$  and critical path  $T_{\text{CP}}$ . Assume that  $T_{\text{mult}} = 0.06\mu\text{s}$  and  $T_{\text{add}} = 0.04\mu\text{s}$ . (2 p)
  - Modify the filter structure so that the critical path contains one multiplication and at most two additions. You may use pipelining and change the order in which the additions are performed. The magnitude function of the filter must not be changed. (2 p)

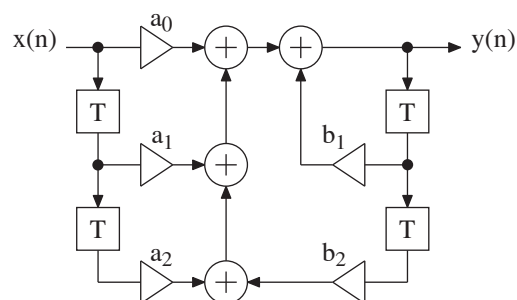

Fig. 1.

- 4) Realize a third-order Causer wave digital filter satisfying the highpass filter requirements in Fig. 2. Start from a lowpass filter that is realized with a  $\pi$ -net with load and generator resistances of  $1 \Omega$ . Use Richard's variable  $\Psi = (z - 1)/(z + 1)$  and directly interconnected adaptors with reflection-free ports. Draw the wave-flow graph and compute the adaptor coefficients. (10 p)

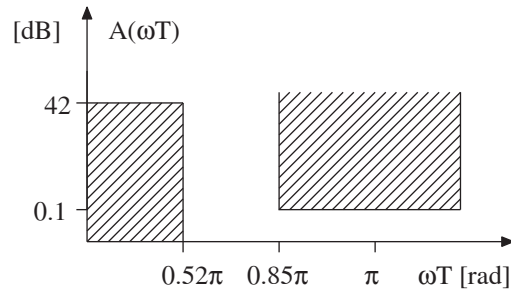

Fig. 2.

- 5) An FIR filter is realized according to Fig. 3 where  $h(0) = 0.01$ ,  $h(1) = 0.05$ ,  $h(2) = 0.12$ , and  $h(3) = 0.15$ .
- a) Scale the filter using safe scaling. Assume that the input signal is scaled and that two's-complement arithmetic is used. Compute the scaling constant/constants and show where it/they should be inserted in the filter. (5 p)
- b) Compute the output noise variance as well as the change in SNR (signal-to-noise ratio) at the output that is obtained when the unscaled filter is replaced with the scaled filter. Assume that quantization (rounding) is performed after each multiplication, and that the quantization can be modeled as additive white noise with the variance  $Q^2/12$  (in case of multiplications by  $2^{-k}$ ,  $k$  integer, these are for simplicity assumed not to contribute any noise). (5 p)

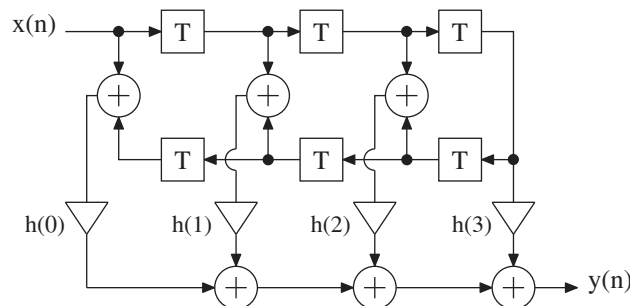

Fig. 3.

- 6 a) Compute the adaptor coefficients for the filter in Fig. 4a. The filter realizes a Causer filter with poles in the z-plane as given below. (7 p)

$$p_0 = -0.7149986$$

$$p_{1,2} = -0.7106323 \pm j0.5021211$$

- b) Assume that the filter in Fig. 4a has a magnitude function according to Fig. 4b. Sketch the magnitude function for the filter in Fig. 4c. (3 p)

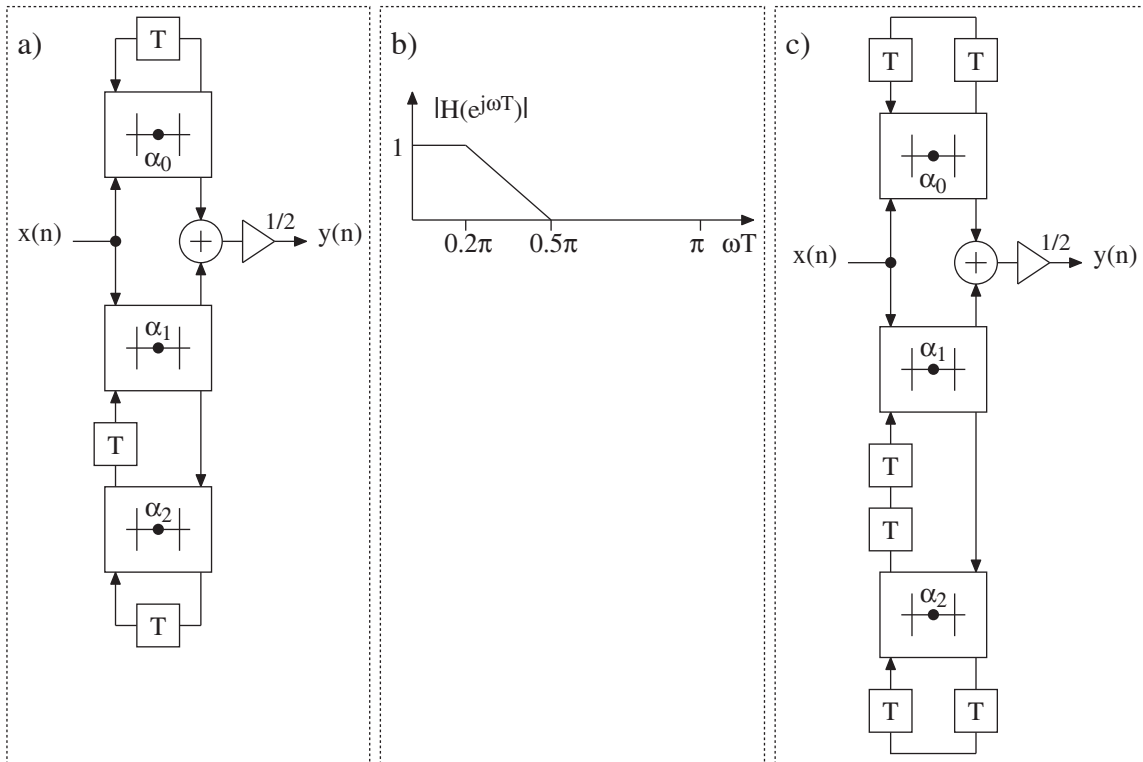

Fig. 4.

- 7) Sketch the spectra for the signals  $y_i(n)$ ,  $i = 1, 2, 3, 4, 5$ , in Fig. 5. (10 p)

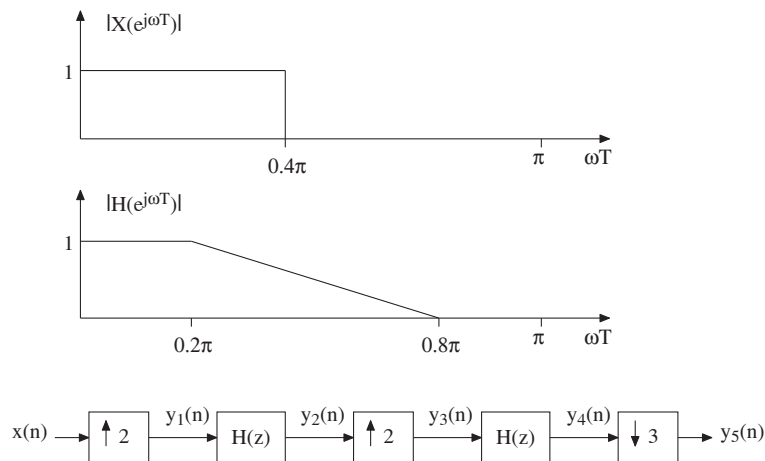

Fig. 5.